

Marquee® Lighting Control Console

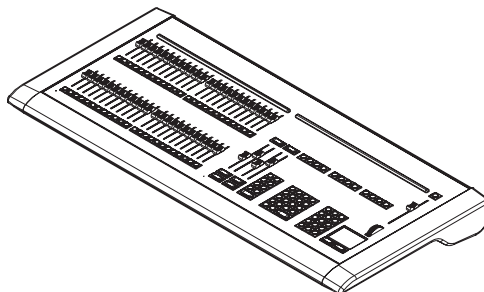

Overview

The Marquee® Lighting Control Console from Entertainment Technology is a professional-grade tracking console capable of controlling any level of performance. It is a true last-action tracking console that will run live performance, operate as a conventional preset desk, and provide complete support for palettes and other automated lighting functions.

The Marquee console utilizes an embedded Microsoft® Windows® XP processor, which ensures that the console will not become obsolete. Advanced software replaces the command structure of traditional DOS-based tracking consoles with a fast and familiar Graphic User Interface (GUI), much like a personal computer, complete with Internet Explorer and Media Player.

Designed with emerging industry standards in mind, the Marquee console is ACN ready, and uses Ethernet and USB connections to extend its control, support, and output. Rear expansion and USB ports provide seamless integration with any combination of additional wing panels or other accessories. As lighting control needs change, so can the Marquee. New points of control can be added through simple, inexpensive hardware upgrades, and if you need more control channels or the latest version of the Marquee operating software, you can download with just a click of a button.

Applications

- Universities
- Schools
- Local and Regional Theatres
- Houses of Worship
- TV Studios
- Special Events / Trade Shows
- Touring Shows
- Hotels / Hospitality

Features

- 128 Memory Control Channels (expandable)
- 48 Single Scene Manual Control Channels
- 24 Dual Scene Manual Control Channels
- 48 Manual Submasters with individual bump buttons and integrated LED
- Unlimited Virtual Submasters
- 1024 DMX Output (Ethernet expandable to 32,768)
- Unlimited Cue Lists with unlimited number of cues
- True Last-Action Tracking Operation
- 32-bit fades with fade times from 1/100 second to 20 days
- Integrated Moving Light Patch Feature
- Complete Abstract Fixture Libraries
- Support for four optional Slider Wing Panels & one optional Button Array Wing Panel
- WYSIWYG support
- Windows® XP Embedded Processor
- Installed Media Player, Browser, E-mail, and PDF Reader
- Active On-Line Technical Support
- Free Off-Line Editor Available
- Upgradeable Control and Hardware

Ordering Info

MQ-128	Marquee Lighting Control Console
MQ-128-2V	Marquee Lighting Control Console with Dual Monitor Support
MQ-512-PKG	Marquee Lighting Control Console with 512 Control Channels, 2 Slider Wing Panels, and 2 LittLite® Worklights

Optional Accessories*

MQ-SWP	24 Slider Wing Panel
MQ-BWP	Button Array Wing Panel
MQ-MUG	MIDI/SMPTE Interface Option Card
MQ-SUG	LYTEmode® Architectural Interface Option Card
MQ-RFUW	Remote Focus Unit - wired
MQ-RFU	Remote Focus Unit - wireless
MQ-LL	2 LittLite® Worklights
LCD-17	17" Flat Panel LCD Video Display
MQ-CRC	Marquee Console Roadcase

* items sold separately

Entertainment Technology

a Genlyte company

10911 Petal Street • Dallas, Texas 75238
1-800-223-9477 • www.etdimming.com

Marquee® Lighting Control Console

Specifications

General

- 128 channel memory operation (expandable)
- 1,024 DMX512 output
- 32,768 channel Ethernet support
- Unlimited cues
- Unlimited groups
- Unlimited submasters
- Abstract fixture library
- Windows® XP embedded processor
- Installed Media Player, Internet Browser, E-mail, and PDF Reader
- Supports Pathport and proposed ACN and RDM protocols
- Off-line editor
- Free remote video support

Playback Controls

- 24 channel two-scene operation (expandable)
- 48 channel single-scene operation (expandable)
- 48 submasters with individual bump buttons and integrated LED (expandable)
- Two timed/manual fader pairs
- True Last Action Tracking operation
- Unlimited cue lists with unlimited simultaneous fades
- Integrated track pad
- Level wheel
- Configurable grand master and blackout button
- Touchscreen video display support

Display Functions (Requires VGA Monitor)

- Live editing
- Blind editing
- Channel status for simultaneous Cue Fades
- Patch (Channel / Moving Light)
- Setup
- Fader / Submaster / Save / Hardware Status
- Virtual Submasters
- Moving light attribute grid
- Grand Master level
- Printed reports in PDF format

Software

- Dedicated Microsoft® Windows XP embedded software
- Marquee software powered by Horizon® Control, Inc.

Control Features

- Split up/down fade times
- Split up/down wait times
- Follow time
- Part cues
- Cue loops
- Fixture check
- Fixture labels
- Preset focuses
- Preset or tracking style operation
- 32-bit fades
- Fade times from 1/100 second to 20 days
- Pre-programmed effects editor
- Moving light patch
- Astronomical time clock and time events
- Macros

Interface

- DMX512 outputs (2)
- Ethernet connection
- Remote trigger inputs (2)
- CD-ROM drive
- Single VGA output (dual optional)
- Gooseneck worklight connection (2)
- Auxiliary USB connections (5)
- Marquee expansion ports (3)

Power Requirements

- Processor 100-240 Volts AC, 47-63 Hz, 1.6 Amp [Max]
- Console 100-240 Volts AC, 50-60 Hz, 1.8 Amp [Max]

Console Physical

- Weight: 32 lbs. (14.5 Kg)
- Dimensions: 37.5" W x 17.5" D x 3.25" H
95.25 cm W x 44.45 cm D x 8.25 cm H

Processor Physical

- Weight: 7.4 lbs. (3.4 Kg)
- Dimensions: 18.25" W x 9.0" D x 2.5" H
46.36 cm W x 22.86 cm D x 6.35 cm H

MARQUEE CONSOLE

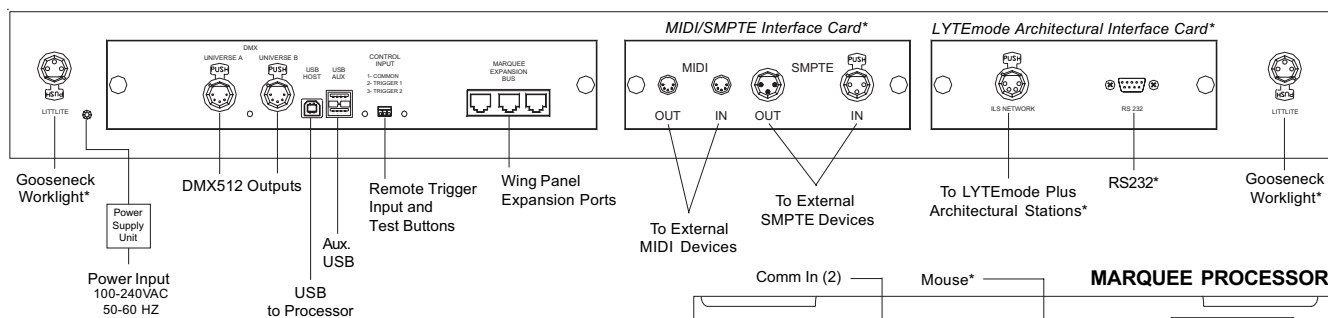

* items sold separately

MARQUEE PROCESSOR

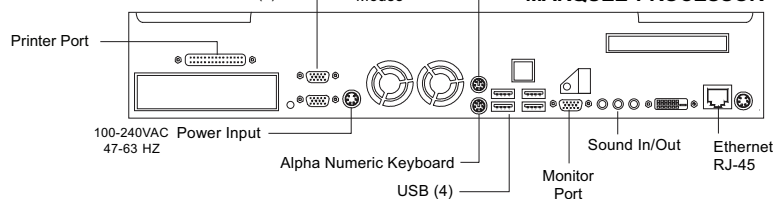

This product may be covered by one or more of the following U.S. Patents: #4,413,211; 4,430,576; 4,465,956; 4,733,138; 4,792,731; 4,880,950; 4,988,840; 4,992,709; 5,004,969; 5,004,969; 5,128,654; 5,153,816; 5,189,259; 5,194,858; 5,239,255; 5,239,255; 5,371,439; 5,371,444; 5,506,480; 5,636,111; 5,642,104; 5,646,490; 5,814,550; 5,821,704; 5,920,156; 5,930,126; Des. #307,578; 333,124; 435,203; 440,207; License #4482844; 5,004,969; 5,239,255; and corresponding foreign patents. Other Utility, Design and Foreign Patents Pending. We reserve the right to change details of design, materials and finish in any way that will not alter the installed appearance or reduce function performance. Specifications are subject to change without notice.



Entertainment Technology

a Genlyte company
10911 Petal Street • Dallas, Texas 75238

For technical/sales assistance, call: 1-800-223-9477

Made in USA © 2005 Genlyte Group LLC

www.etdimming.com P/N: 87-0480B